

DEVELOPMENT OF MODELING APPROACHES FOR NUCLEAR THERMAL PROPULSION TEST FACILITIES. D. R. Jones,¹ D. C. Allgood² and K. Nguyen³, ¹NASA John C. Stennis Space Center (Mail Code EA33, SSC, MS 39529; daniel.r.jones@nasa.gov), ²NASA John C. Stennis Space Center (Mail Code EA33, SSC, MS 39529; daniel.c.allgood@nasa.gov) and ³NASA John C. Stennis Space Center (Mail Code EA33, SSC, MS 39529; ke.nguyen@nasa.gov)

Introduction: High efficiency of rocket propulsion systems is essential for humanity to venture beyond the moon. Nuclear Thermal Propulsion (NTP) is a promising alternative to conventional chemical rockets with relatively high thrust and twice the efficiency of the Space Shuttle Main Engine. NASA is in the process of developing a new NTP engine, and is evaluating ground test facility concepts that allow for the thorough testing of NTP devices. NTP engine exhaust, hot gaseous hydrogen, is nominally expected to be free of radioactive byproducts from the nuclear reactor; however, it has the potential to be contaminated due to off-nominal engine reactor performance. Several options are being investigated to mitigate this hazard potential with one option in particular that completely contains the engine exhaust during engine test operations. The exhaust products are subsequently disposed of between engine tests.

For this concept (see Figure 1), oxygen is injected into the high-temperature hydrogen exhaust that reacts to produce steam, excess oxygen and any trace amounts of radioactive noble gases released by off-nominal NTP engine reactor performance. Water is injected to condense the potentially contaminated steam into water. This water and the gaseous oxygen (GO₂) are subsequently passed to a containment area where the water and GO₂ are separated into separate containment tanks.

Analysis Approach: Computational modeling and analytical techniques are used to investigate some key components of a Total Containment Test Facility. For example, a fully-coupled, multi-physics, Computational Fluid Dynamics (CFD) analysis approach is used to evaluate NTP ground test facility system concepts. The use of CFD techniques provides a detailed description of the physical processes and, importantly, provides a means to visualize the physical flow processes. The multi-physics approach requires simultaneous simulations of processes such as transient real-gas hydrogen flow through a supersonic diffuser, LO₂/GH₂ combustion at high speeds, and multi-phase condensation and evaporation of water sprays in a reacting flow environment. However, multiphase reactive CFD simulations are not easy or straightforward to obtain. In addition, fully coupling these flow simulations with transient thermal analysis of heat exchangers and thermal protection systems significantly increases the complexity. Work has started to investigate, implement and begin validating the options available for modeling multi-phase reactive flows in a fully coupled multi-physics framework. CFD tools under evaluation include CRUNCH CFD, ANSYS CFD (FLUENT and/or CFX), and Loci/CHEM.

The design of facility systems also involves the use of both in-house and traditional, commercially-available software tools that enable the evaluation of, for example, heat exchanger performance, fluid flow in piping, pipe routing and vessel sizing. These analysis tasks are routinely performed to support the liquid propulsion devices tested at the various NASA SSC test stands. This experience provides an excellent springboard to begin developing modeling tools and techniques for NTP systems. Work has started with tailoring these in-house and commercially-available software tools to support the development of NTP facility design concepts.

Results: Computational fluid dynamic (CFD) techniques are used to simulate the flow of the high-temperature hydrogen exhaust from the NTP engine through a supersonic diffuser and the subsequent combustion of that hydrogen with injected oxygen. Using

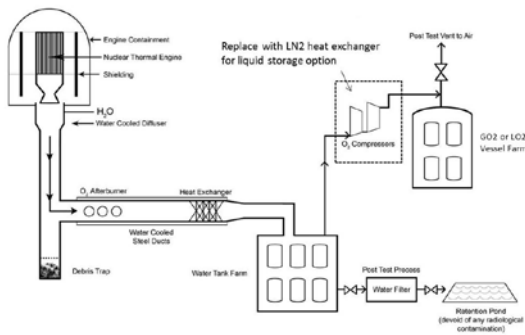

Figure 1. Nuclear Thermal Propulsion (NTP) Total Containment Test Facility Concept.

CFD, preliminary sizing of the supersonic diffuser has been completed for a full-scale NTP engine. Future modeling efforts are being focused on optimizing the supersonic diffuser and combustor concept. In addition, identifying a method to model cooling water injection and phase change will be pursued.

After cooling the combustion gases down to condense the water out of the exhaust products, the non-condensable products (i.e., GO₂) need to be stored. Several options are being considered for minimizing the storage volume requirements and the associated hazard risks of storing oxygen. Currently, two options are being investigated for oxygen retention; (1) compressed gas storage system and (2) liquid storage. The compressed gas option pumps residual GO₂ from the containment area from near ambient pressure to a high-pressure storage vessel. The liquid storage option flows GO₂ from the containment area through a liquid nitrogen (LN₂) heat exchanger to liquefy the GO₂ and store the liquefied oxygen (LO₂) in a vacuum/LN₂ jacketed tank for storage for subsequent disposal. Using an in-house modeling tool, preliminary evaluation of the necessary water and GOX collection vessel sizes has been completed for the testing of a full-scale NTP test article for a range of conditions.